

REVISION HISTORY			
REV.	DESCRIPTION	DATE	DRAWN BY
1	ORIGINAL PRINT	11/2/2016	N. LAWRENCE
2	UPDATED HEX BORE TOL, ADDED CHAMFERS, AMDS-1	2/18/2020	N. MASSOUDA

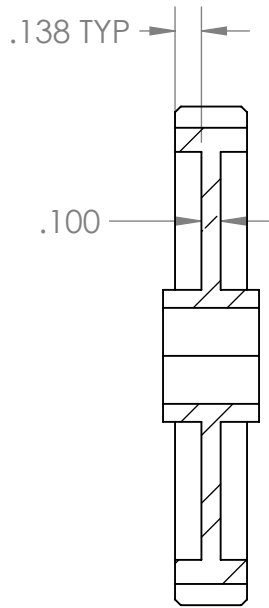

SECTION A-A

.506  
.501 HEX THRU  
TIMING TO TEETH  
NOT REQUIRED

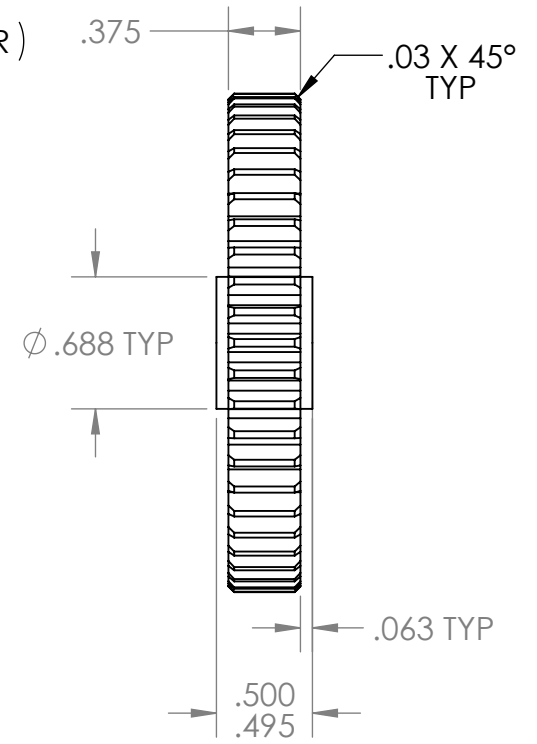
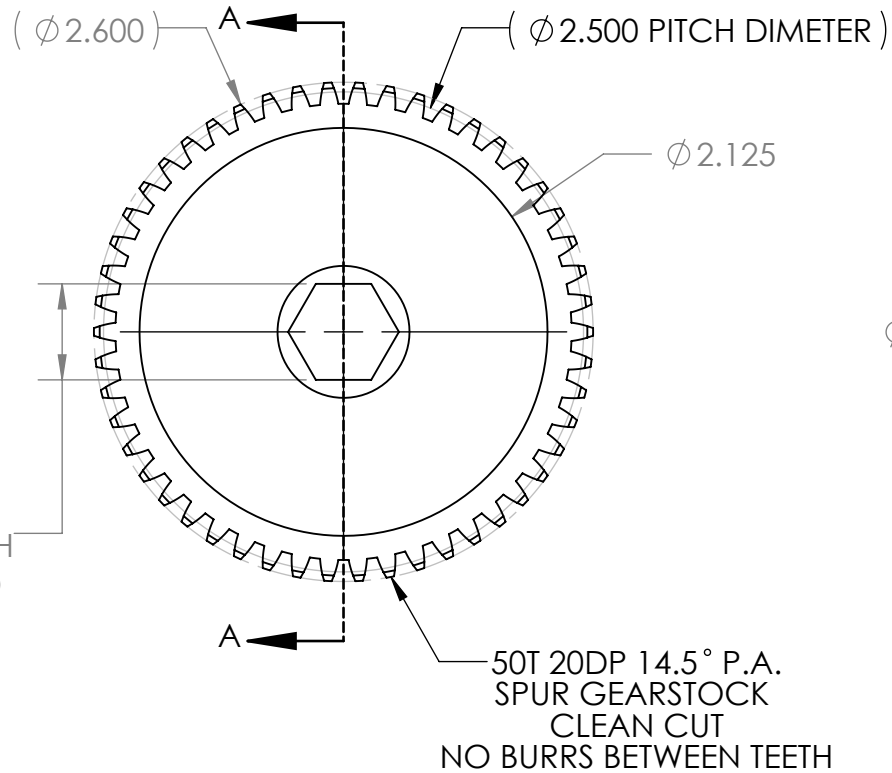

\*\*\* SEE CAD FOR ADDITIONAL TOOLPATH INFO\*\*\*

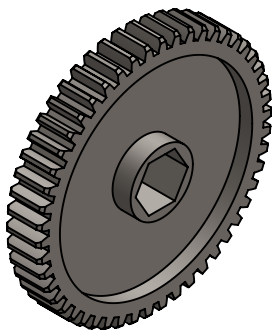

UNLESS OTHERWISE SPECIFIED:		COMMENTS:	
<b>DIMENSIONS ARE IN INCHES</b>		DUAL DIMENSIONS ARE IN MILLIMETERS.	
TOLERANCES:		BREAK ALL SHARP EDGES	
FRACTIONAL	±1/16		
ANGULAR: MACH	±1°		
ANGULAR: BEND	±5°		
ONE PLACE DECIMAL	±0.1		
TWO PLACE DECIMAL	±0.01		
THREE PLACE DECIMAL	±0.005		
FOUR PLACE DECIMAL	±0.0005		
MATERIAL	4140 STEEL	NAME	DATE
FINISH	DEBURR & ZINC PLATE	CHECKED	
		ENG APPR.	
		MFG APPR.	
	DO NOT SCALE DRAWING	Q.A.	



TITLE:  
50T 20DP 14.5PA  
0.500 HEX BORE GEAR

SIZE	DWG. NO.	REV
<b>A</b>	am-3488	2

SCALE: 1:1 WEIGHT: SHEET 1 OF 1